

# Tutorial: Emptiness in Phonological Theory

Phonological Theory Agora, Paris  
October 6, 2017

Sabrina Bendjaballah  
(Laboratoire de Linguistique de Nantes, CNRS & Université de Nantes)

Eva Zimmermann  
(Leipzig University)

## Contents

<b>1. A typology of emptiness</b>	<b>2</b>
1.1. What emptiness can do for us: A potpourri of arguments . . . . .	3
1.2. How emptiness looks like: Defective/Incomplete autosegmental structures . . . . .	4
1.3. Detecting Emptiness: Arguments for emptiness in lexicon/phonology/phonetics . . . . .	7
<b>2. Emptiness and phonological theory</b>	<b>8</b>
2.1. Emptiness in Government Phonology . . . . .	8
2.1.1. The phonological ECP in standard GP . . . . .	9
2.1.2. The syntactic ECP . . . . .	10
2.1.3. Different types of empty categories . . . . .	12
2.2. Emptiness in Optimality Theory . . . . .	15
2.2.1. Emptiness in the input . . . . .	15
2.2.2. Emptiness in the output . . . . .	16
2.2.3. Brief illustrations: Dutch and Turkish . . . . .	17
2.3. Adding another level of emptiness: Containment/Turbidity . . . . .	19
<b>3. Case studies</b>	<b>20</b>
3.1. Taubergrund German: Emptiness and absence of lengthening . . . . .	20
3.2. Upper Austrian German . . . . .	22
3.3. Berber nouns and the initial empty CV . . . . .	24
3.4. Zacatepec Chatino: Different levels of defaultness . . . . .	26
<b>4. Discussion/Open questions</b>	<b>30</b>

Goal:

- Give an overview of the many concepts of and arguments for emptiness
- Argue that emptiness is pervasive under most theoretical assumptions about phonology
- Show empirical arguments for emptiness and argue that it allows to predict apparently (morpho-phonological) exceptions from standard assumption of phonological theory

## 1. A typology of emptiness

- ‘positions in phonological representations that have no direct phonetic counterpart’ (Cavirani and van Oostendorp, 2017)
- ‘categories not present in the phonetic signal’ (Bérces, 2013)
- ‘morpho-syntactic objects that native speakers do not hear’ (Bendjaballah and Haiden, 2008, 24)
- ‘items that are not pronounced but have an effect on the [...] phonology of adjacent elements or other elements of the structure containing them’ (Hartmann et al., 2008, 1)
- ‘a covert morphological element that hides its existence well and is betrayed only by the effect it has on its phonological environment, as the culprit’ (Zonneveld, 1982, 357)

*A preliminary thought*

- if emptiness is defined solely as elements lacking a direct acoustic counterpart, emptiness would be pervasive: many elements have no direct phonetic cue!
- the main portion of a stop (=its closure), for example, is acoustically zero...

(1) *Spectrogram of a stop (Trommer (2012); <https://commons.wikimedia.org/w/index.php?curid=255892>)*

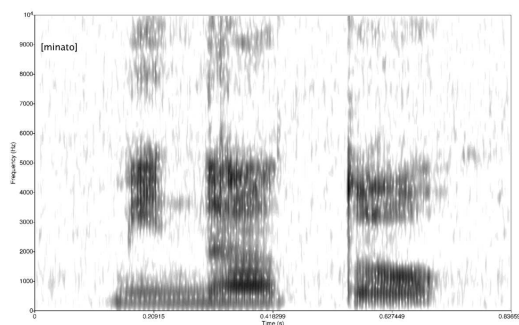

m i n a t o

## 1.1. What emptiness can do for us: A potpourri of arguments

- if elements have no direct phonetic counterpart but are assumed to exist nevertheless, they are usually visible/have an effect in the phonology: they hence have an **indirect phonetic realization** (e.g. in blocking/triggering a phonological process)

- e.g. *Dutch* (Zonneveld, 1982; van Oostendorp, 2005)

- an optional process of /n/-deletion in the coda is impossible in the 1SG
- follows if the 1SG-morpheme is an empty mora and the stem-final /n/ is hence in the onset position of an empty syllable where deletion is impossible

→ an **empty element hence blocks a phonological process**

### (2) *Dutch: Melodically empty prosodic position* (van Oostendorp, 2005)

a. *Adjective*

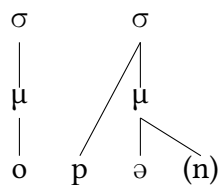

b. *Verb, 1SG*

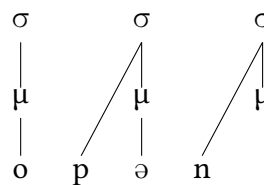

- e.g. *Ahtna* (Rice, 2011)

- final C's of CVVC-stems undergo voicing (of fricatives prevocally) and spirantization (of stops in certain verbal aspects) whereas final C's of CVC-stems don't
- this follows if final C's of CVC and CVVC are syllabified differently and the final C of a CVVC-stem is syllabified as onset of an empty nucleus: onsets are then voiced
- since only full vowels license the voicing (e.g. Pigott, 1999), it then only surfaces before a vowel (=suffix following the stem)

→ the **empty element hence triggers (over-)application of a process**

### (3) *Ahtna: Melodically empty prosodic position triggers a process* (Rice, 2011)

a. *CVC: No voicing of a coda*

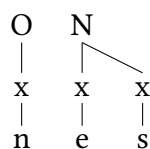

b. *CVVC: Voicing in the onset*

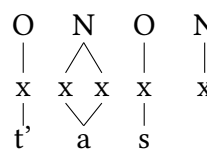

- cf. the assumption that all default vowels/schwas are empty prosodic positions (Anderson, 1982; van Oostendorp, 2003; Onuma, 2015) *Todo oder weg!*

- e.g. *Polish jers* (Spencer, 1986; Szypra, 1992):

- some words have vowels alternating with zero
- this follows if jers are radically underspecified segmental root nodes that are devoid of any melodic features and hence block syllabification

- vocalization of jers only applies if they are followed by an otherwise unsyllabifiable consonant

→ an **empty position explains the unexpected alternation of an element with zero**

(4) *Polish: Melodically empty prosodic position results in V-∅ alternation (Szypra, 1992, 294)*

a. Underlying: /sVnV/ 'dream'      b. Vocalization of word-medial jer: NOM.SG

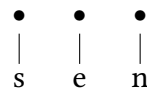

c. No vocalization: GEN.SG

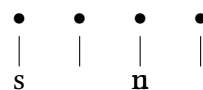

• e.g. *Macushi Carib (Kager, 1997):*

- gradient rhythmic vowel deletion is phonologically incomplete: Deletion occurs in free variation with vowel reduction, preserves syllabicity (and foot structure), and has phonetic cues of a vowel (e.g. open transition)

- this follows if vowel deletion is the loss of vocalic features (could be interpreted as both (5-a) or (5-b))

→ an **empty element has a different phonetic effect** than a fully specified one

(5) *Macushi Carib: Gradient vowel deletion (Kager, 1997)*

a. Option 1: Empty moras

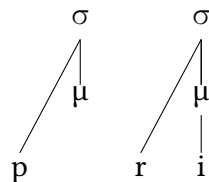

b. Option 2: Empty vowels

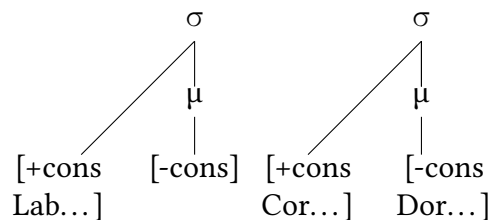

- cf. the general argument for catalexis: empty moras dominated by syllables to optimize prosodic structure; i.e. avoid degenerate feet (Kiparsky, 1991; Kager, 1999)

- cf. also, for example, Kaye (1990b); Kaye et al. (1990): empty nuclei are realized if they are followed by another non-realized empty nucleus

## 1.2. How emptiness looks like: Defective/Incomplete autosegmental structures

- 'autosegmental representations do not only facilitate the expression of emptiness but they directly lead to its necessary assumption' (Bérces, 2013, 259)

- emptiness from an autosegmental perspectives implies a picture of **completeness**: every structure that lacks any of the parts of (6) can be considered to be empty

(6) A ‘complete’ autosegmental structure (for a word)

[kī́tá] ‘hammock’

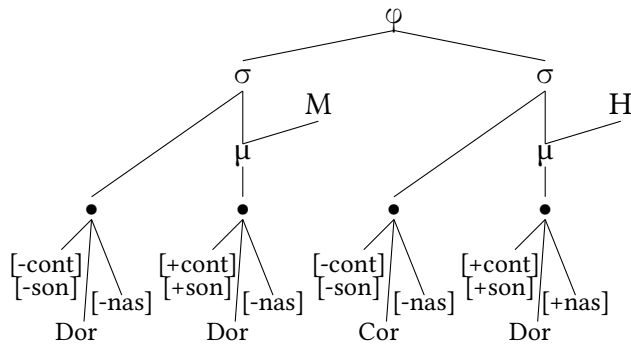

(Zacatepec Eastern Chatino (Villard, 2015, 63))

- main type of ‘empty’ element: empty prosodic/skeletal position **without melodic content**
- but emptiness can also include **underspecification** (i.e. segments lacking certain features/elements, Archangeli (1988))
- e.g. *Turkish* (Inkelas, 1995)
  - some stops alternate between begin voiced in the onset and voiceless in the coda; others are consistently voiced or voiceless
  - this follows if some stops are underspecified for [ $\pm$ voice] and hence undergo voicing-assimilation but fully specified obstruents are non-undergoers

(7) *Underspecification Turkish* (Inkelas, 1995)<sup>1</sup>

a. *Underlying: /kanaT/* ‘wing’

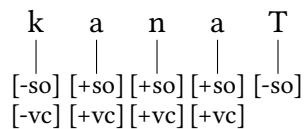

b. *Voiceless: Word-final*

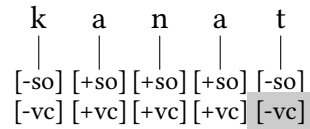

c. *Voiced: ACC-suffix follows*

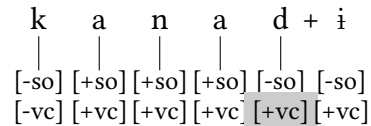

- similar account for vowel alternations in Yucatec Mayan (Krämer, 2001) or voicing alternations in Breton (Krämer, 2000)
- if the absence of a feature is ‘emptiness’, then the assumption of privative features in fact implies lots of featural ‘emptiness’ – but this is not ‘interesting’ emptiness in the sense that a contrast/unexpected behaviour is explained
- emptiness can also include autosegmental elements that **lack higher prosodic structure**

<sup>1</sup>Grey elements in the depictions are usually epenthetic.





- other examples: liaison in French follows from consonants without a position on the skeletal tier (Tranel, 1995, 1996, e.g.)
- under such a general autosegmental view, **emptiness is in fact everywhere** and not a special at all

### 1.3. Detecting Emptiness: Arguments for emptiness in lexicon/phonology/phonetics

- a typology of different types of emptiness and their surface effect/contrasts with non-empty elements is given in (11) where  represents a morpheme (=the 'form' side of a morpho-syntactic feature bundle) and the grey shadings phonological/phonetic content
- (11-a) is true  $\emptyset$ -exponence: the existence of such a marker is deduced since it, for example, blocks other markers or because exponence for a certain category is assumed to be obligatory (Trommer, 2012)
- (11-b) would be non-concatenative morphology or morpheme-specific phonology under a concatenativist view of morphology (Lieber, 1992; Stonham, 1994; Saba Kirchner, 2010; Trommer, 2011; Bermúdez-Otero, 2012; Bye and Svenonius, 2012)
- how direct the phonetic realization of the 'empty' element in (11-b) is crucially depends on the theoretical account – under a floating feature analysis (10), the empty element has a direct phonetic effect on another segment
- the Dutch example (2) would be of this type although it is not a classic instance of non-concatenative morphology: the empty element is visible in the phonology and blocks a process, it hence has an indirect phonetic effect on a neighbouring morpheme
- the Turkish underspecification example (7) is of type (11-c): the elements that are missing underlyingly are provided in the phonology and the empty element is different from a non-empty one phonetically
- the Macushi Carib example (5) illustrates (11-d): an empty element remains empty in the phonology and is hence different from a non-empty element in the phonology and also in its phonetic interpretation
- (11-e) is very similar to (11-b) since an effect of the empty element can be seen on an adjacent element; in contrast to (11-b), the morpheme containing the empty element also has direct phonetic realization; it is hence not completely empty
- in all these types, the difference between being empty or non-empty is a **lexical contrast**
- in (11-f), however, it is a **phonological contrast** that is predictable from the phonological context and is hence a derived property of the phonology

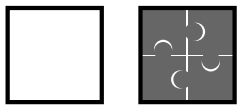
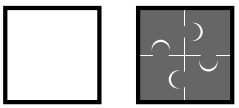
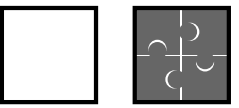
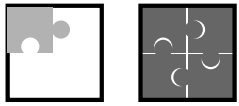
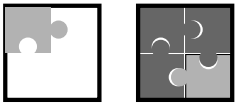
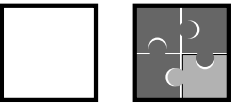
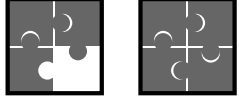
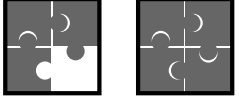
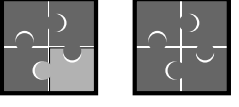
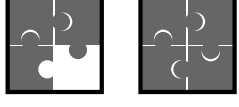
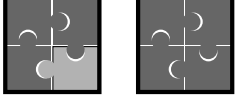
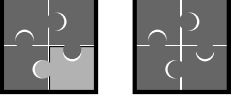
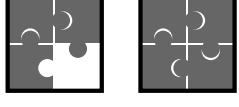
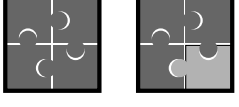
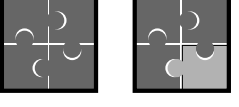
(11)

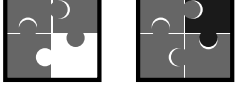
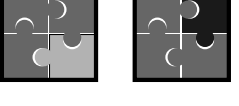
	Lexicon	Phonology	Phonetics	e.g.
a. <i>∅-morpheme</i>				e.g. 3.Ps-prefix in Mojave (Trommer, 2012)
b. <i>Effect of EC only on other morphemes</i>				Dutch (2), T. Popoluca (10), Somali (17), Chaha (18), T. German §3.1., Berber §3.3.
c. <i>EC is empty in phonology and phonetics is different from non-empty one</i>				Macushi Carib (5), Zacatepec Chatino §3.4.
d. <i>EC might be 'filled' in the phonology but its behaviour is different</i>				Turkish (7), Russian (8)
e. <i>EC triggers exceptional phonology (on adjacent elements)</i>				Yine (9)
f. <i>EC derived in the phonology: Context predicts phonological/phonetic difference</i>				Ahtna (3)

## 2. Emptiness and phonological theory

### 2.1. Emptiness in Government Phonology

- General background (2.1.1. and 2.1.2.)

- EC = an object with no apparent phonetic realization, but with a manifestation in the phonological string ⇒ EC can be detected only by consideration of the structure around
- EC must be licensed/their presence must be legitimated. In GP: the phonological ECP governs their distribution. *E.g.* Proper Government readily accounts for vowel-zero alternations.
- Open discussion: Phonological ECP inspired by the syntactic ECP. ECP and government have been abandoned in syntax for various reasons. How far can the parallelism be maintained?



- Emptiness and defectiveness (2.1.3.)
  - As soon as we postulate an EC, we postulate an object  $\Rightarrow$  notion of defectiveness: how defective is a given category?
  - In a representational framework, different representations/levels of defectiveness  $\Rightarrow$  explore the notion with the typology of Bendjaballah and Haiden (2008).
  - Open discussion: Defectiveness and recoverability

### 2.1.1. The phonological ECP in standard GP

#### Background

- The phonological ECP (Kaye et al. (1990): 219)  
A position may be uninterpreted phonetically if it is properly governed.
- Proper Government (Kaye et al. (1990): 219)
  - The governor may not itself be governed.
  - The domain of proper government may not include a governing domain.
- The Projection Principle (Kaye et al. (1990): 222)  
Governing relations are defined at the level of lexical representation and remain constant throughout a phonological derivation.
- Various amendments/reformulation since Kaye et al. (1990), see e.g. Kaye (2000)
  - The phonological ECP: A p-licensed (empty) category receives no phonetic interpretation.
  - p-licensing:
    - (a) PGed (empty) nuclei are p-licensed;
    - (b) Domain-final (empty) categories are p-licensed (parametrised);
    - (c) Magic licensing: s+C sequences p-license a preceding empty nucleus Kaye (1992).  
Nota: (b) and (c) = much debated issues, cf. Scheer (2004) for a review.
  - PG: a properly governs b if
    - (a) a and b are adjacent on the relevant projection;
    - (b) a is not itself licensed;
    - (c) neither a nor b are government licensers
  - Government licensing: a nuclear position is a government licenser if its onset
    - (a) governs a preceding rimal complement;
    - (b) or is the head of a branching onset

#### Illustration

- V/zero alternation

(12) Somali

- gud $\emptyset$ ba:  
cross.present.1s
- gudb $\emptyset$ ta:, \*gud $\emptyset$ b $\emptyset$ ta:  
cross.present.2s

- c. gudub∅, \*gud∅b∅  
*cross.imperative.s*
- d. bahar∅ < Ar.bah∅r∅  
*sea*
- e. fasir∅ < Ar. fassara  
*explain.imperative.s*

- What happens if an empty N is not PGed? It is realized either by propagation from the context (e.g. an adjacent vowel, (12)a-d), or by the default/epenthetic vowel (12)e.
- Nota: vs in the syntax: no realization, the sentence is agrammatical

- Intervening government domains/Government licensing

- a is a gvt licenser (i) V<sub>1</sub>rkV<sub>2</sub>; \*∅rkV<sub>2</sub> (ii) V<sub>1</sub>krV<sub>2</sub>; \*∅krV<sub>2</sub>
- b is a gvt licenser (i) rkV<sub>1</sub>CV<sub>2</sub>; \*rk∅CV<sub>2</sub> (ii) krV<sub>1</sub>CV<sub>2</sub>; \*kr∅CV<sub>2</sub>
- ⇒ a condition on the target of PG: government licenser cannot be PGed. Cf. cyclicity...

(13) French

- a. dægʁe ; d∅gʁe  
*degree*
- b. maʁgəvit; maʁg∅vit  
*daisy*
- c. gʁənɥ; \*gʁ∅nɥ  
*frog*

- See e.g. Charette (1990)
- Scheer (1999): data are better captured in a CVCV-framework

- Predictions on the distribution of natural classes of consonants
- Important tool for the understanding of various phenomena in phonology

### 2.1.2. The syntactic ECP

#### Background

- Government (Chomsky (1986): 8)  
A governs B if and only if
  - (i) A is a governor; and
  - (ii) A m-commands B; and
  - (iii) no barrier intervenes between A and B.

Maximal projections are barriers to government.  
Governors are heads.

- ECP (Chomsky (1986): 17)  
Traces must be properly governed.

- Proper Government (Chomsky (1986): 17)  
A properly governs B if and only if A theta-governs B or A antecedent-governs B.
  - (i) A theta-governs B if and only if A governs B and A theta-marks B.
  - (ii) A antecedent-governs B if and only if A governs B and A is coindexed with B.
- 2 types of government:
  - A theta-governs B: A and B are two different heads (lexical selection)
  - A antecedent-governs B: B is another occurrence of A.
- 2 types of conditions:
  - structural: command (C-command, m-command)
  - lexical: there must be a selection relationship between the head and the position it governs (complement of a lexical head)

*Phonological ECP // syntactic ECP?*

- ECP: applies to movement traces in syntax (objects with lexical content) vs empty positions in phonology do not arise as a consequence of movement
- PG: antecedent-government: relation between 2 occurrences of the same object vs in phonology.
- Barriers (minimality condition), intervening governing domains.
- Minimality Condition (Chomsky (1986):42, reproduced in Kaye et al. (1990): 225)  
In the configuration ... $\alpha$  ... $[\gamma$  ... $\delta$  ... $\beta$  ...]
  - $\alpha$  does not govern  $\beta$  in the above configuration if  $\gamma$  is a projection of  $\delta$  excluding  $\alpha$ , or
  - $\alpha$  does not govern  $\beta$  in the above configuration if  $\gamma$  is the immediate projection of  $\delta$  excluding  $\alpha$
- Constraint on the target of government: cyclicity (head cannot move to a head that has already moved)
- Head Movement Constraint (Travis (1984)): stepwise head to head movement (intervening heads cannot be skipped), adapted from Haegeman (1991): 606.
  - $*[_{CP} [Have_i] [_{IP} you [I could] [_{VP} t_i done such a thing]]]?$
  - $[_{XP} H_i [_{YP} t_i [_{ZP} t_i [_{HP} t_i]]]]$
  - $*[_{XP} H_i [_{YP} Y [_{ZP} t_i [_{HP} t_i]]]]$
- Three types of EC in syntax: silent functional and lexical categories, traces, ellipsis (SOS intro).  
... in phonology?
- Nota: Infrasegmental level
  - Rice (1992)... Pöchtrager (2006)

- Internal structure of segments/"strength": Harris (1990): "I discuss a condition on phonological representations which requires that a segment occupying a governed position be no more complex than its governor, where complexity is straightforwardly calculated in terms of the number of elements of which a segment is composed", Rice (1992): "A consonant A governs an adjacent consonant B if A has less SV structure than B"

*wanna contraction*

- (14) a. Bill is the man I want to succeed.  
 b. Bill is the man I wanna succeed.

- (a) is ambiguous:  $i_1$  = I hope Bill succeeds,  $i_2$  = I hope to follow Bill  
 (b) is not ambiguous:  $i_2$  = I hope to follow Bill
- (a) has 2 analyses, one corresponding to each of the 2 interpretations:
  - Bill is the man I want [tr] to succeed =  $i_1$
  - Bill is the man I want to succeed [tr] =  $i_2$
- *wanna* contraction blocked by intervening [tr]: it applies only if *want* and *to* are adjacent  $\Rightarrow$  necessity of ECs
- In fact (a) Bill is the man I want [PRO] to succeed [tr] and (b) Bill is the man I want [tr] to succeed  $\Rightarrow$  necessity of distinguishing between different types of EC: *wanna* contraction is blocked by [tr], not by [PRO]

2.1.3. *Different types of empty categories*

*EC in an autosegmental framework*

- Levels: segmental, skeletal
- Concentrate on the interface with the syntax  $\Rightarrow$  will not address:
  - EC below the segmental level (subsegmental emptiness, underspecification), see case study X?
  - the differences due to the position in the syllable structure: see John (2014) for a review (empty onsets: Clements and Keyser (1983); empty codas: Kaye and Lowenstamm (1984); empty nucleus: Fudge (1976), Anderson (1982), Wiese (1986), Hall (1989), Kaye (1990a) among many others)
- Add : syntactic terminals
- The interface is the skeleton (Bendjaballah and Haiden (2003), Bendjaballah and Haiden (2008))

*Exploring autosegmental deficiency*

FF syntax	x	x	x	$\emptyset$	$\emptyset$	$\emptyset$	x	$\emptyset$
skeleton	x	x	$\emptyset$	x	$\emptyset$	x	$\emptyset$	$\emptyset$
melody	x	$\emptyset$	x	x	x	$\emptyset$	$\emptyset$	$\emptyset$
	(16)a	(15)a	(15)b	(15)c	(15)d	(15)e	(16)b	(16)c

- Deficiency = mismatch between the 3 levels of autosegmental representations: FF-syntax, CV-skeleton, melody.
- 8 configurations, 5 of which are relevant

(15) 5 relevant configurations

a. positional marker

FF-syntax: A  
 |  
 CV skeleton: CV

melody:

b. floating marker

FF-syntax: A

CV skeleton:

melody:  $\alpha$

c. templatic expletive

FF-syntax:

CV skeleton: CV  
 |  
 melody:  $\alpha$

d. floating segment

FF-syntax:

CV skeleton:

melody:  $\alpha$

e. empty site

FF-syntax:

CV skeleton: CV

melody:

(16) 3 irrelevant configurations

- a. fully overt marker, no EC

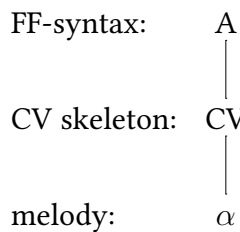

- b. empty syntactic category

FF-syntax: A

CV skeleton:

melody:

- c. silence = not a category

FF-syntax:

CV skeleton:

melody:

*Three well-known configurations*

- Positional marker (15)a

Propagation and reduplication with morpho-syntactic value (Classical Arabic: form II kattaba / form III ka:taba, Guerssel and Lowenstamm (1990); CV-reduplication, Kiparsky (1986) for a survey, etc.)

Nota: Manifestation is not always 'direct' (i.e. visible via lengthening); it includes e.g. stress/tone shift:

(17) Somali feminine marker

- a. ínan 'boy' (masc)  
b. inán 'girl' (fem)

– Generalization: Feminine nouns have their tonal accent on the last V/mora, masculine nouns have their tonal accent on the penultimate V/mora.

– Analysis Godon (1998): the feminine marker is a  $\emptyset$  suffix

Consequence: both masc and fem nouns have their tonal accent on the same position:

í<sub>2</sub>na<sub>1</sub>n 'boy' (masc)

iná<sub>2</sub>n $\emptyset$ <sub>1</sub> 'girl' (fem)

⇒ apparent stress shift stems from the presence of an empty suffix in the feminine

- Floating marker (15)b

Tone markers, palatalization, labialization, nasalisation, consonant mutation, voicing with morpho-syntactic value (featural affixes, e.g. Akinlabi (2011) and references therein).

They appear only in the lexicon: no skeletal support, need a host to be phonetically realized (“features have to be “licensed” (i.e. their occurrences have to be sanctioned) in order to get phonetically realized, therefore featural affixes must associate with a licenser in the stem or elsewhere.”, Akinlabi (2011))

Nota: An intermediate configuration: *lame markers* (Lowenstamm (2000))

- (18) Chaha feminine suffix
- a.  $\sqrt{\text{dgs}}$  ‘give a feast’  
 $\text{di}g\text{is}$  (masc)  
 $\text{di}g\text{i}f$  (fem)
  - b.  $\sqrt{\text{ktf}}$  ‘chop meat’  
 $\text{ki}t\text{i}f$  (masc)  
 $\text{ki}t\text{i}f$  (fem)
  - c.  $\sqrt{\text{smA}}$  ‘listen’  
 $\text{si}ma$  (masc)  
 $\text{si}m\text{ä}$  (fem)
  - d. “that suffix involves a template inherently unable, on account of its shortness, to guarantee autonomous realization of its associated segmental content” (Lowenstamm (2000): 189)

- Floating segment (15)d  
 Final consonants in French liaison (Clements and Keyser (1983), Encrevé (1988), *etc.*)

*In quest of the two remaining configurations*

- Templatic expletive (15)c: object with a segmental spell-out but no morphosyntactic value
- Empty site (15)e: object with no intrinsic segmental spell-out and no morphosyntactic value

## 2.2. Emptiness in Optimality Theory

### 2.2.1. Emptiness in the input

- a necessary consequence from Richness of the Base (Prince and Smolensky, 1993/2002): empty things are as expected/possible in the input as non-empty elements
- under the radical view that emptiness is everything departing from the ‘completeness’ in (6) and assumption that non-contrastive information (like syllabification under some views) is not part of the input, non-empty inputs are in fact downright impossible
- Lexicon Optimization (19) hence apparently excludes contrastive emptiness in input structures
- however, if one takes into account that empty elements discussed above have at least some indirect phonetic effect on neighbouring morphemes, ‘contrastive emptiness’ is possible if LO includes surface alternations of morphemes (cf. modified (20))
- (some examples show that (20) is still insufficient: alternations in the vicinity of morphemes must be taken into account as well)

- (19) *Lexicon Optimization* (Prince and Smolensky, 1993/2002, 209)  
 Suppose that several different inputs  $I_1, I_2, \dots, I_n$  when parsed by a grammar  $G$  lead to

corresponding outputs  $O_1, O_2, \dots, O_n$ , all of which are realized as the same phonetic form  $\varphi$ — these inputs are all *phonetically equivalent* with respect to  $G$ . Now one of these outputs must be the most harmonic, by virtue of incurring the least significant violation marks: suppose this optimal one is labelled  $O_k$ . Then the learner should choose, as the underlying form for  $\varphi$ , the input  $I_k$

(20) *Alternation-sensitive restatement of Lexicon Optimization (Inkelas, 1995, 209)*

Given a grammar  $G$  and a set  $S = \{S_1, S_2, \dots, S_i\}$  of surface phonetic forms for a morpheme  $M$ , suppose that there is a set of inputs  $I = \{I_1, I_2, \dots, I_j\}$ , each of whose members has a set of surface realizations equivalent to  $S$ . There is some  $I_i \in I$  such that the mapping between  $I_i$  and the members of  $S$  is the most harmonic with respect to  $G$ , i.e. incurs the fewest marks for the highest ranked constraints. The learner should choose  $I_i$  as the underlying representation for  $M$ .

- a special type of emptiness with an indirect phonetic effect is predicted by the REALIZE MORPHEME constraint in Kurisu (2001): it demands some phonological effect for every morpheme (cf. Wolf (2007) for an excellent summary of different existing REALIZE MORPHEME-concepts in the literature)
- it hence can predict phonological changes for morphemes that are completely empty phonologically, hence only consist of morpho-syntactic features
- this allows a unified account for non-concatenative morphology and especially non-concatenative allomorphy

(21) REALIZE MORPHEME (Kurisu, 2001, 39)

Let  $\alpha$  be a morphological form,  $\beta$  be a morphosyntactic category, and  $F(\alpha)$  be the phonological form from which  $F(\alpha+\beta)$  is derived to express a morphosyntactic category  $\beta$ . Then RM is satisfied with respect to  $\beta$  iff  $F(\alpha+\beta) \neq F(\alpha)$  phonologically.

### 2.2.2. Emptiness in the output

- a necessary consequence from the fact that **constraints are violable**
- returning to (6), various constraint/s (families) have been proposed to ensure ‘completeness’:
  - for the **prosodic** structure: HEADEDNESS (Selkirk, 1995), (biconditional) PROJECT (X,Y) (van Oostendorp, 1995), PARSE-INTO-X (Spaelti, 1994; Ito and Mester, 2009), or LICENSE-X (Kiparsky, 2003),...
  - logic of most of these constraint systems: start at the segmental level and require proper parsing for all higher levels
  - system in (22) is an example for a bidirectional system requiring both parsing into higher and lower structure (necessary for, e.g. catalectic moras (2) or (5))

- (22) a.  $\mu > V$ : Assign a violation mark for every  $\mu$  that does not dominate a vowel.  
 b.  $\mu < \sigma$ : Assign a violation mark for every  $\mu$  that is not dominated by a  $\sigma$ .

- for **segmental features**, usually feature-specific constraints like (23) are assumed

(23) SPEC[F] ‘[F] must be specified’ (Dresher, 2003, 159)



– and for tone, the standard constraint is (24)

(24) SPECIFY: Assign a violation mark for every TBU not associated to a tone (Yip, 2002)

- in the original containment-based PARSE/FILL OT-model, emptiness was an integral part of the output since it distinguished epenthetic from non-epenthetic things (25):
- ‘PARSE and FILL are Faithfulness constraints: they declare that perfectly well-formed syllable structures are those in which input segments are in one-to-one correspondence with syllable positions. Given an interpretive phonetic component that **omits unparsed material and supplies segmental values for empty nodes**, the ultimate force of PARSE is to forbid deletion; of FILL, to forbid insertion.’ (Prince and Smolensky, 1993/2002, 94; emphasis ours)

(25) *Parse-Fill model (Prince and Smolensky, 1993/2002, 94)*

- PARSE: Underlying segments must be parsed into syllable structure.
- FILL: Syllable positions must be filled with underlying segments.

### 2.2.3. Brief illustrations: Dutch and Turkish

#### Dutch

- /n/-deletion triggered by  $*n_{\text{CODA}}$  (alternative would be combination of  $*n$  and MAXONSET)
- ranking for /n/-deletion:  $*n_{\text{CODA}} \gg \text{MAXC}$
- ranking ensuring that  $\mu$  remains empty, is not deleted, and blocks /n/-deletion:  $\text{DEPV}, \text{MAX}\mu \gg \mu > V$
- that an empty  $\mu$  can not be inserted to prevent /n/-deletion:  $\text{DEP}\mu \gg \text{MAXC}$
- (that high-ranked DEP V makes no misprediction for potentially  $\mu$ -less V's: high-ranked MAXV)

(26) *n-deletion for codas*

	$\mu_1$ o		$\mu_2$ p		$\mu_2$ ə		n	$*n_{\text{CODA}}$	DEPV	DEP $\mu$	MAX $\mu$	$\mu > V$	MAXC
a.	$\sigma$   $\mu_1$   o		$\sigma$ / \ \ / $\mu_2$   ə				n	*!					
b.	$\sigma$   $\mu_1$   o		$\sigma$ / \ \ / $\mu_2$   ə				n			*!		*	
c.	$\sigma$   $\mu_1$   o		$\sigma$ / \ \ / $\mu_2$   ə										*

(27) *Empty mora blocks n-deletion*

	$\mu_1$ o	$\mu_2$ p	$\mu_3$ ə	n	$*n_{\text{CODA}}$	DEP <sub>V</sub>	DEP <sub><math>\mu</math></sub>	MAX <sub><math>\mu</math></sub>	$\mu > V$	MAX <sub>C</sub>
a.	$\sigma$   $\mu_1$   o	$\sigma$   $\mu_2$   p	$\sigma$   $\mu_3$   ə	n					*	
b.	$\sigma$   $\mu_1$   o	$\sigma$   $\mu_2$   p	$\sigma$   $\mu_3$   ə	n	*!			*!		
c.	$\sigma$   $\mu_1$   o	$\sigma$   $\mu_2$   p	$\mu_3$ ə						*	*!
d.	$\sigma$   $\mu_1$   o	$\sigma$   $\mu_2$   p	$\sigma$   $\mu_3$   ə	n		*!				

*Turkish*

- HAVE[vc] demands that every segment must be specified for some value of [ $\pm$ voice]
- the default to fill this empty feature slot for an obstruent is [-voice] (28) but in intervocalic position, this preference is overridden by the dispreference for voiceless elements intervocalically (29)

(28) *Underspecified segment: Filled with default-value*

	k	a	n	a	T	HAVE[vc]	*V[-vc]V	*VcDOBS	DEP[vc]
	[-so] [-vc]	[+so] [+vc]	[+so] [+vc]	[+so] [+vc]	[-so]				
a.	[-so] [-vc]	[+so] [+vc]	[+so] [+vc]	[+so] [+vc]	[-so]	*!			
b.	[-so] [-vc]	[+so] [+vc]	[+so] [+vc]	[+so] [+vc]	[-so] [-vc]				*
c.	[-so] [-vc]	[+so] [+vc]	[+so] [+vc]	[+so] [+vc]	[-so] [+vc]			*!	*

(29) *Underspecified segment: Filled with special value in marked context*

	k	a	n	a	T	+	i					
									HAVE[vc]	*V[-vc]V	*VcDOBS	DEP[vc]
	[-so]	[+so]	[+so]	[+so]	[-so]	[-so]						
	[-vc]	[+vc]	[+vc]	[+vc]		[+vc]						
a.	k	a	n	a	T		i		*!			
	[-so]	[+so]	[+so]	[+so]	[-so]	[-so]						
	[-vc]	[+vc]	[+vc]	[+vc]		[+vc]						
b.	k	a	n	a	t		i			*!		*
	[-so]	[+so]	[+so]	[+so]	[-so]	[-so]						
	[-vc]	[+vc]	[+vc]	[+vc]	[-vc]	[+vc]						
c.	k	a	n	a	d		i				*	*
	[-so]	[+so]	[+so]	[+so]	[-so]	[-so]						
	[-vc]	[+vc]	[+vc]	[+vc]	[+vc]	[+vc]						

### 2.3. Adding another level of emptiness: Containment/Turbidity

- multiplies possible empty structures: they can be really empty or only linked to an element via an invisible/uninterpreted association, i.e. they are ‘**phonologically contentful empty elements**’ (Cavirani and van Oostendorp, 2017)
- Cavirani and van Oostendorp (2017) argue that this is a good prediction: it allows a representational difference between empty elements that do not license (=really empty) and those that are empty but are still able to license empty nuclei (=have invisible/abstract relation to their structure)
- this hence predicts a ‘hierarchy of emptiness’: truly empty elements, those filled ‘invisibly’, and non-empty ones
- e.g. *Dutch*
  - no word-final devoicing ([xɛlø:vən] ‘faiths’ – [xɛlø:f] ‘faith’) in 1.Sg forms ([xɛlø:v] ‘I believe’)
  - follows under GP if the 1.Sg is an empty vowel that is **invisibly linked to some content** and hence able to license voiced obstruent
  - (Turbidity notation: the downward arrow denotes the abstract projection relation (=not pronounced!); the upward arrow the pronounced pronunciation relation)

(30) *Dutch: Licensed of non-empty nuclei (Cavirani and van Oostendorp, 2017)*

a. *Devoicing: /geloov/ 'belief'*      b. *No devoicing: /geloov/ + 1.SG*

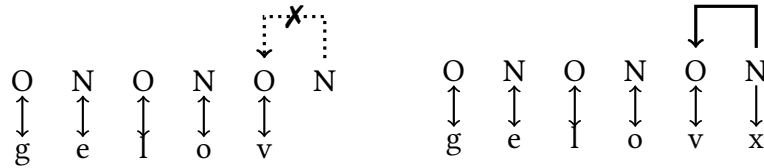

c. *No devoicing: /geloov/ + /ə/ INF*

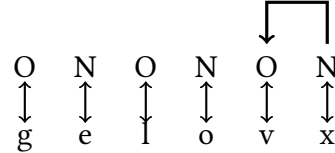

### 3. Case studies

#### 3.1. Taubergrund German: Emptiness and absence of lengthening

⇒ The plural morpheme in Taubergrund German is an empty mora that does not dominate any segment in the output but blocks expected vowel lengthening: the indirect phonetic effect of the empty element is hence the absence of an expected phonological process.

(31) *Catalectic mora in Taubergrund German (Seiler, 2008)*

Underlying:	prosodic position without melodic content
Phonology:	visible = sufficient to satisfy the word minimality condition
Phonetic:	indirect effect = no lengthening

- in Taubergrund German, formation of the plural shows an apparent vowel shortening for monosyllabic nouns with a long vowel in the singular

(32) *'Shortening' in Taubergrund German (Heilig, 1898, 78)*

SINGULAR		PLURAL
ri:s	'crack'	ris
fi:ʃ	'fish'	fiʃ
ʃni:ds	'cut'	ʃnids
fle:k	'blot'	flek
ri:t	'ride'	ret
di:ʃ	'table'	diʃ
ʃdri:k	'rope'	ʃdrik

#### Analysis

- independent observation: the language employs a bimoraic word minimality condition in all contexts except the plural of those nouns
- one can hence assume that the nouns in (32) are underlyingly monomoraic and a **mora is affixed in the plural that remains empty but makes vowel lengthening obsolete**
- without any additional mora, vowel lengthening for monomoraic words is expected (33-a)

- the plural-mora is affixed and remains catalectic: it does not have a direct phonetic effect since it does not dominate any segment (33-b)
- the syllable in (33-b), however, is now bimoraic and additional vowel lengthening is harmonically bounded

(33) *Plural formation as catalectic  $\mu$ -affixation*

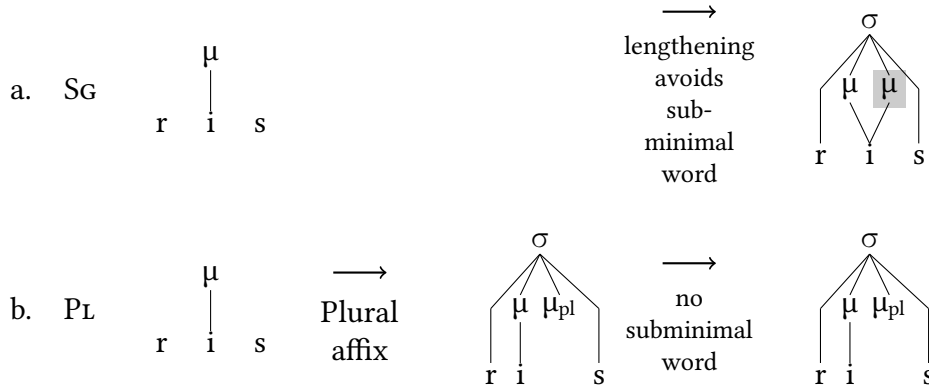

- a theoretical implementation inside OT can be based on the constraints (34) and the rankings:
  - every PrWd must dominate at least two moras and mora epenthesis+vowel lengthening ensures this for monomoraic bases:  $\text{MINWD} \gg \text{DEP}(\mu)$
  - a floating mora must be integrated under a syllable node but never dominates segments:  $\text{DEPAL}(\mu\text{-S}) \gg \mu\text{-S}$
  - that the  $\mu$  is integrated under a  $\sigma$  node follows both from  $\mu\text{-}\sigma$  and  $\text{MINWD}$ ; there is hence no good ranking argument for  $\mu\text{-}\sigma$

- (34)
- $\text{MINWD}$ : Assign a violation mark for every prosodic word node containing at least two moras.
  - $\text{DEP}(\mu)$ : Assign a violation mark for every output mora without a correspondent.
  - $\text{DEPAL}(\mu\text{-S})$ : Assign a violation mark for every association line between mora  $\mu$  and segment S if  $\mu$  and S are present in the input but not associated.
  - $\mu\text{-S}$ : Assign a violation mark for every mora not dominating a segment.
  - $\mu\text{-}\sigma$ : Assign a violation mark for every mora not dominated by a syllable.

(35) *Lengthening in the singular*

$\mu_1$ r i s	MINWD	DEPAL( $\mu$ -S)	DEP( $\mu$ )	$\mu > \sigma$	$\mu > S$
a. $\sigma$ r $\mu_1$ s r i s	*!				
b. $\sigma$ r $\mu_1$ $\mu$ s r i s			*		

(36) *No lengthening in the plural*

$\mu_1$ $\mu_2$ r i s	MINWD	DEPAL( $\mu$ -S)	DEP( $\mu$ )	$\mu > \sigma$	$\mu > S$
a. $\sigma$ r $\mu_1$ $\mu_2$ s r i s	*!			*	
b. $\sigma$ r $\mu_1$ $\mu_2$ s r i s		*!			
c. $\sigma$ r $\mu_1$ $\mu_2$ s r i s					*
d. $\sigma$ r $\mu_1$ $\mu$ $\mu_2$ s r i s			*!		*

3.2. Upper Austrian German

Kühnhammer (2004) Upper Austrian German exhibits a similar phenomenon, with a major difference, though: C-lengthening in the plural (known as *isochrony* in the traditional literature)

(37) Upper Austrian German

- a. fi:f  
'fish' (sg)
- b. fi:f̥f̥  
'fish' (pl)

- "heavy head: every foot must have a heavy head  $[[CVCV]_H CV]_F$ "

- sg: unmarked way to respect heavy head = spreading of V<sub>1</sub>
- pl: “morphological influence, for which C<sub>2</sub> and V<sub>2</sub> act as a ‘landing site’ in phonological structure, will trigger the second possibility: spreading of C<sub>3</sub>”; “internal plural formation by identification of a derivational syllable.”

*A new perspective: diminutive formation*

- 2 diminutive suffixes: -l and -erl
- A concatenative operation with stem-internal effects
- Possible effects of -l/-erl suffixation:
  - vowel-alternation (Umlaut)
  - stem-internal length-alternation
- 2 groups of nouns: (38), (39)

(38) V:C → VCC

base.sg	diminutive.sg	base.pl	gloss
long V	<b>short V</b>	<b>short V</b>	
ʁo:s	ʁessl	ʁessa	<i>horse</i>
ko:pf	køppfi	keppf	<i>head</i>
plø:ts	plattsl	pletts	<i>place</i>
dø:x	daxxi	dεçça	<i>roof</i>

(39) V:C → V:C

base.sg	diminutive.sg	base.pl	gloss
long V	<b>long V</b>	<b>long V</b>	
bʁe:d	bʁe:dl	bʁe:da	<i>board</i>
flø:g	fla:gi	fle:g	<i>hit/blow</i>
by:d	by:dl	by:da	<i>image</i>

- No straightforward phonological condition that defines the 2 groups:

(40) Minimal pair

base.sg	diminutive.sg	base.pl	gloss
sø:g	sakki	sekk	<i>bag</i>
sø:g	sa:gi	?se:g	<i>saw</i>

- Distribution of length-alternation:
 

base.sg	V:C	dim.sg	VCC	⇔	base.pl	VCC
		dim.sg	V:C	⇔	base.pl	V:C
- New generalization: Shortening in the plural is not specific of the plural, the same class of nouns is shortened in the diminutive.
- Same length-alternation in the diminutive and in the plural, but diminutive form ≠ plural form.  
⇒ V-shortening is not a specificity of the plural or the diminutive but a property of a class of nouns.





(44) Free State, fem.sg:  $\theta$ axxamt

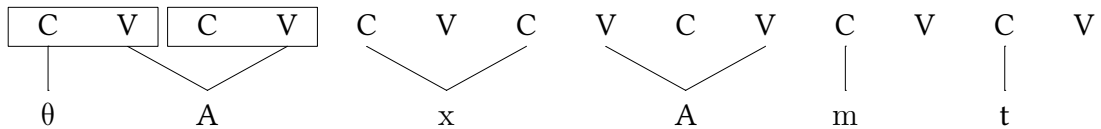

(45) Construct State, fem.sg:  $\theta$ axxamt

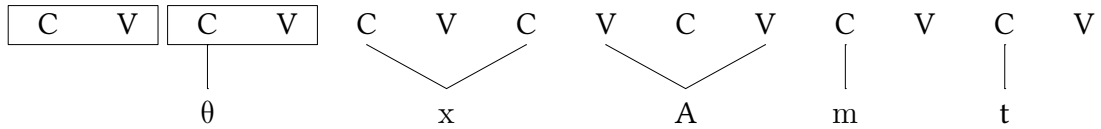

(46) Free State, fem.pl:  $\theta$ ixxamin

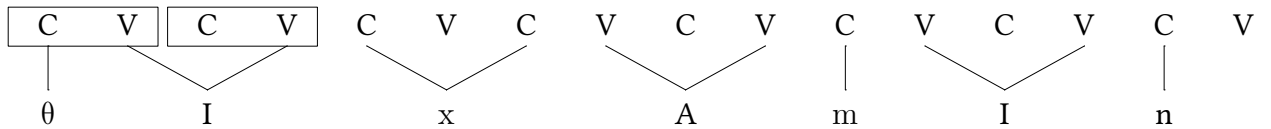

(47) Construct State, fem.pl:  $\theta$ ixxamin

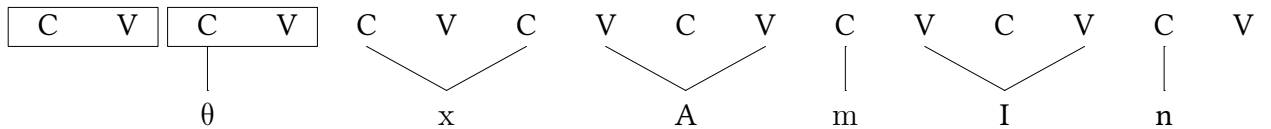

- Outer CV-unit in the CS is an empty category. Possible types: positional marker (15)a, empty site (15)e, or silence (16)c.
- Guerssel (1987): The Free State involves two overt markers K and D, while the CS is only marked overtly for D. Outer CV marks K, inner CV marks D.

(48) Free State, fem.sg:  $\theta$ axxamt

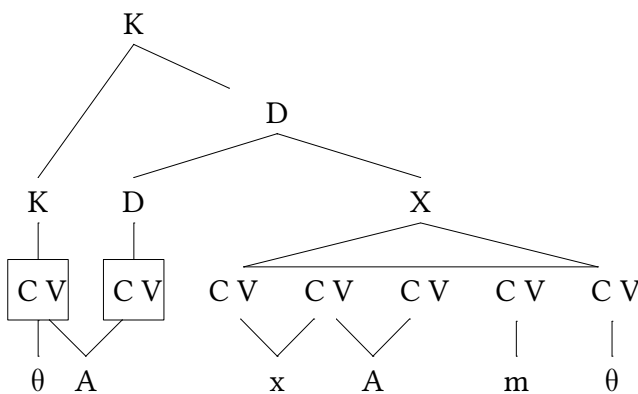

(49) Construct State, fem.sg:  $\theta$ axxamt

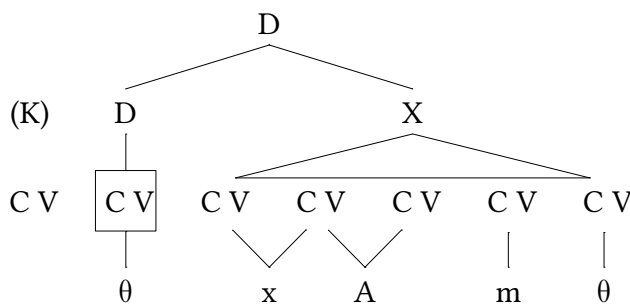

- Feminine: Gender is a feature of D, not K.

- CS: Fem spelled out on the position associated with D.
- FS: Fem spelled out on the position associated with K: D has overtly raised to K
- The status of the initial empty CV in the CS
  - K necessary in the syntax: 2 options (15)a, or (16)b.
  - K not necessary in the syntax: 4 options (15)a, (15)e, (16)b, or (16)c
- The reality of the initial empty CV
  - $g\theta\text{əxxam}t$  ‘in the room’ =  $g\theta\text{əxxam}t$  ‘in-room.CS’
  - Prepositions are floating markers (Bendjaballah and Haiden (2013)), they need a host-C to be realized  
 $\Rightarrow$  (15)a or (15)e.
- If (15)a, then prepositions must be case-markers:

(50) Initial CV as positional marker of K:  $g\theta\text{əxxam}t$  ‘in the room’

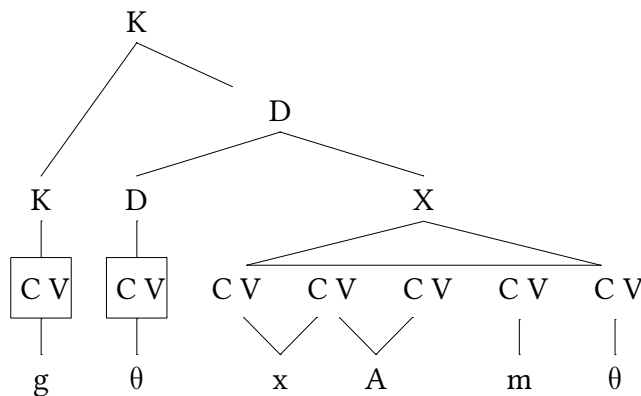

- P however are prepositional, not case-markers (Bendjaballah and Haiden (2013)).  
 $\Rightarrow$  (15)e:

(51) Initial CV hosting floating P:  $g\theta\text{əxxam}t$  ‘in the room’

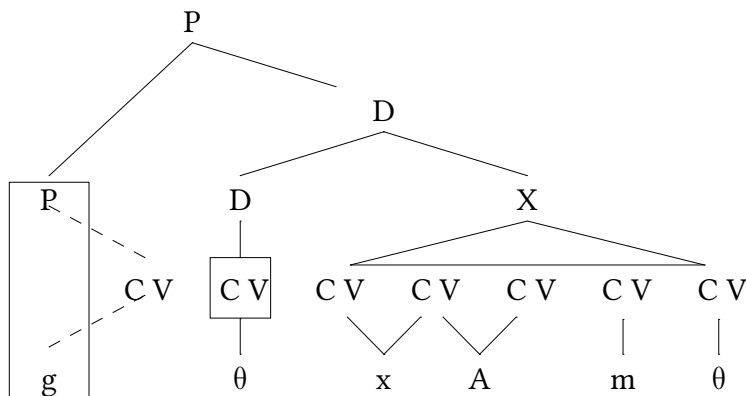

### 3.4. Zacatepec Chatino: Different levels of defaultness

$\Rightarrow$  Some TBU's remain empty in the phonology and are interpreted with a phonetic default in Zacatepec Chatino – a tone-less TBU is (phonetically and phonologically) different from a tone-less TBU that gets a phonological default tone.

(52) *Phonetic default in Zacatepec Chatino (Zimmermann, 2017b)*

Underlying:	TBU without tone
Phonology:	no tone assigned: no intervention for the OCP
Phonetic:	interpreted with a default

- Zacatepec Chatino: Otomanguan language, spoken in the town of San Marcos Zacatepec by around 300 people (all above 50 years of age)
- data from Villard (2015) (cf. also Villard (2010); Villard and Woodbury (2012))
- a tone language: TBU=μ; 4 level tones low (=a<sup>L</sup>), mid (=a<sup>M</sup>), high (=a<sup>H</sup>), and superhigh (=a<sup>S</sup>), and 2 rising contours LH and LS
- in phrasal contexts: final H and S **spread** to some words (53-a-d) but not others (53-e)

(53) *H/S-spreading and default L's and (Villard, 2015, 184+187)*

	UNDERLYING	SURFACE	
a.	kwi <sup>M</sup> na <sup>H</sup> kula /M.H/ /X.X/	kwi <sup>M</sup> na <sup>H</sup> ku <sup>H</sup> la <sup>H</sup> [M.H][H.H]	'old snake'
b.	yu <sup>L</sup> sin <sup>LS</sup> kula /L.LS/ /X.X/	yu <sup>L</sup> sin <sup>LS</sup> ku <sup>S</sup> la <sup>S</sup> [L.LS][S.S]	'old sea turtle'
c.	tit <sup>y</sup> uk <sup>L</sup> wa <sup>LS</sup> naten <sup>L</sup> /X.L.LS/ /X.L/	ti <sup>L</sup> t <sup>y</sup> uk <sup>L</sup> wa <sup>LS</sup> na <sup>S</sup> ten <sup>L</sup> [L.L.LS][S.L]	'twelve people'
d.	tit <sup>y</sup> uk <sup>L</sup> wa <sup>LS</sup> kwana <sup>M</sup> /X.L.LS/ /X.M/	ti <sup>L</sup> t <sup>y</sup> uk <sup>L</sup> wa <sup>LS</sup> kwa <sup>S</sup> na <sup>M</sup> [L.L.LS]S.M]	'twelve thieves'
e.	tit <sup>y</sup> uk <sup>L</sup> wa <sup>LS</sup> mu <sup>L</sup> l <sup>y</sup> LS /X.L.LS/ /L.M/	ti <sup>L</sup> t <sup>y</sup> uk <sup>L</sup> wa <sup>LS</sup> kwa <sup>L</sup> na <sup>M</sup> [L.L.LS][L.M]	'twelve mules'

- follows if there are underlyingly toned and tone-less TBU's in ZAC and final H and S spread to all following tone-less TBU's
- tone-less TBU's preceded by M, a tone-less TBU, or no TBU are realized as L
- follows under the assumption that L is the default tone provided for otherwise tone-less TBU's

(54) *Default-L (Villard, 2015, 184+187)*

	UNDERLYING	SURFACE	
a.	kwana kula /X.X/ /X.X/	kwa <sup>L</sup> na <sup>L</sup> ku <sup>L</sup> la <sup>L</sup> [L.L][L.L]	'old mirror'
b.	nkanan <sup>M</sup> kwila /X.M/ /X.X/	nka <sup>L</sup> nan <sup>M</sup> kwi <sup>L</sup> la <sup>L</sup> [L.M][L.L]	'I looked for fish'
c.	ka <sup>L</sup> kwen <sup>M</sup> kwila /L.M/ /X.X/	ka <sup>L</sup> kwen <sup>M</sup> kwi <sup>L</sup> la <sup>L</sup> [L.M][L.L]	'you will vomit fish'
d.	kwi <sup>M</sup> to <sup>M</sup> kula /M.M/ /X.X/	kwi <sup>M</sup> to <sup>M</sup> ku <sup>L</sup> la <sup>L</sup> [M.M][L.L]	'old hen'

- several words ending in **floating H or LS tones** that are realized on the rightmost tone-less TBU of the following word; potential preceding TBU's become M

(55) *Realization of floating H and LS (Villard, 2015, 187+223+233)*

	UNDERLYING	SURFACE	
a.	kwana <sup>M(H)</sup> kula /X.M (H)/ /X.X/	kwa <sup>L</sup> na <sup>M</sup> ku <sup>M</sup> la <sup>H</sup> [L.M][M.H]	‘old thief’
b.	kwa <sup>M(H)</sup> nkajilyan <sup>M</sup> /M (H)/ /X.X.M/	kwa <sup>M</sup> nka <sup>M</sup> ji <sup>H</sup> lyan <sup>M</sup> [M][M.H.M]	‘already I farted’
c.	kwa <sup>M(H)</sup> nkasa <sup>L</sup> lo <sup>M</sup> /M (H)/ /X.L.M/	kwa <sup>M</sup> nka <sup>H</sup> sa <sup>L</sup> lo <sup>M</sup> [M][H.L.M]	‘already you threw it away’
d.	mul <sup>L</sup> ya <sup>M(LS)</sup> kula /L.M (LS)/ /X.X/	mul <sup>L</sup> ya <sup>M</sup> ku <sup>M</sup> la <sup>LS</sup> [L.M][M.LS]	‘old mule’
e.	naten <sup>L(LS)</sup> kula /X.L (LS)/ /X.X/	na <sup>L</sup> ten <sup>L</sup> ku <sup>M</sup> la <sup>LS</sup> [L.L][M.LS]	‘old people’
f.	kwa <sup>M(H)</sup> nta <sup>M</sup> sa <sup>H</sup> la <sup>M</sup> /M (H)/ /M.H.M/	kwa <sup>M</sup> nta <sup>M</sup> sa <sup>H</sup> la <sup>M</sup> [M][M.H.M]	‘already you are opening it’

- Villard (2015) lists a third floating tone: L

(56) *Realization of floating L (Villard, 2015, 187+246)*

	UNDERLYING	SURFACE	
a.	ʔa <sup>L(L)</sup> nkaji <sup>M</sup> n <sup>y</sup> an <sup>H</sup> /L (L)/ /X.M.H/	ʔa <sup>L</sup> nka <sup>M</sup> ji <sup>M</sup> n <sup>y</sup> an <sup>H</sup> [L][M.M.H]	‘s/he did not ask for it’
b.	ʔa <sup>L(L)</sup> nkajilyan <sup>M</sup> /L (L)/ /X.X.M/	ʔa <sup>L</sup> nka <sup>M</sup> ji <sup>M</sup> lyan <sup>M</sup> [L][M.M.M]	‘I did not fart’
c.	ʔa <sup>L(L)</sup> nkalukwa <sup>LH</sup> /L (L)/ /X.X.LH/	ʔa <sup>L</sup> nka <sup>M</sup> lu <sup>M</sup> kwa <sup>LH</sup> [L][M.M.LH]	‘s/he did not sweep it’
d.	ʔa <sup>L(L)</sup> ntusane <sup>L(L)</sup> /L (L)/ /X.X.L (L)/	ʔa <sup>L</sup> ntu <sup>M</sup> sa <sup>M</sup> ne <sup>M</sup> [L][M.M.M]	‘s/he sprays it’
e.	ʔa <sup>L(L)</sup> nkasa <sup>L</sup> lo <sup>M</sup> /L (L)/ /X.L.M/	ʔa <sup>L</sup> nka <sup>M</sup> sa <sup>M</sup> lo <sup>M</sup> [L][M.M.M]	‘you did not throw it aw.’

- ...but in the majority of contexts, there is no additional L, there are rather multiple additional M’s!
- only in two of the many contexts (57), do we really see the expected behaviour of a floating L-tone

(57) *Floating L: Summary of empirical facts*

	$\mu$	$\mu \mu$	$\mu \mu \mu$
1.	/X/ [ML]	/XX/ [M.L]	/XXX/ [M.M.L]
2.	/L (LS)/ [M (LS)]	/X.L (LS)/ [M.M (LS)]	/X.X.L (LS)/ [M.M.M (LS)]
3.	/L (L)/ [M (L)]	/X.L (L)/ [M.M (L)]	/X.X.L (L)/ [M.M.M (L)]
4.	/M/ [M]	/X.M/ [M.M]	/X.X.M/ [M.M.M]
5.	/M (H)/ [M (H)]	/X.M (H)/ [M.M (H)]	/X.X.M (H)/ [M.M.M (H)]
6.	/M/ [M]	/L.M/ [M.M]	/X.L.M/ [M.M.M]
7.	/M (LS)/ [M (LS)]	/L.M (LS)/ [M.M (LS)]	/X.L.M (LS)/ [M.L.M (LS)]

8.	/LH/ [LH]	/X.LH/ [M.LH]	/X.X.LH/ [M.M.LH]
9.	/LS/ [LS]	/L.LS/ [L.LS]	/X.L.LS/ [M.L.LS]
10.	/M/ [M]	/M.M/ [M.M]	/X.M.M/ [M.M.M]
11.	/H/ [H]	/M.H/ [M.H]	/X.M.H/ [M.M.H]
12.	/ML/ [ML]	/M.L/ [M.L]	/M.M.L/ [M.M.L]
13.	/L (L)/ [L (L)]	/LS.L (L)/ [LS.L (L)]	/M.LS.L (L)/ [M.LS.L (L)]
14.	/M/ [M]	/H.M/ [H.M]	/M.H.M/ [M.H.M]
15.	/L/ [M]	/L.M/ [M.M]	/L.M.L/ [M.M.M]

- the theoretical challenges of the floating tones in ZAC:
  - Why are floating H and LS realized on the rightmost tone-less TBU, ignoring intervening tone-less TBU's?
  - Why do the intervening TBU's become M?
  - Why does the 'floating L' does not result in an additional L-tones but rather additional M-tones in the majority of contexts?

*Analysis*

1. Strong preference for tones to be at the right edge of the phrase
    - triggers H/S-spread to tone-less TBU's (58-a)
    - ensures that floating tones 'float' to the right (58-d)
  2. Insertion of the default-L-tone is impossible between tones of the same morpheme
    - TBU's preceding the landing site of a floating tone hence remain tone-less (58-d)
  3. there are no floating L-tones, only OCP-effects for L-tones
    - no L-epenthesis adjacent to L (58-e)
    - L-deletion adjacent to L (58-f)
  4. tone-less TBU's that don't receive an epenthetic L in the phonology: interpreted as default-M (58-d-f)
- this complex tonology follows in an account that **contrasts a phonological (=L) and a phonetic (=M) default-tone**, TBU's can hence remain empty in the phonology and are interpreted with a phonetic default

(58) *Analysis: Relevant structures (Zimmermann, 2017a)*

INPUT	OUTPUT
<p>a. <i>Tone spreading (of H and S)</i></p> <p style="text-align: center;"> M      H            μ      μ      μ      μ  [kwi    na] [ku    la] </p>	<p style="text-align: center;"> M      H                          μ      μ      μ      μ  [kwi    na] [ku    la] </p>
<p>b. <i>Epenthetic L if no preceding tone</i></p> <p style="text-align: center;"> μ      μ      μ      μ  [kwa    na] [ku    la] </p>	<p style="text-align: center;"> L                          μ      μ      μ      μ  [kwa    na] [ku    la] </p>
<p>c. <i>Epenthetic L if only preceding M</i></p> <p style="text-align: center;"> L      M            μ      μ      μ      μ  [kak    wen] [kwi    la] </p>	<p style="text-align: center;"> L      M      L                          μ      μ      μ      μ  [kak    wen] [kwi    la] </p>
<p>d. <i>Floating tone realization: No epenthesis morpheme-internally!</i></p> <p style="text-align: center;"> M      H                      M                                   μ      μ                      μ      μ  [kwa] [nka    jil    yan] </p>	<p style="text-align: center;"> M                      H      M                                   μ                      μ      μ      μ  [kwa] [nka    jil    yan] </p>
<p>e. <i>No L-epenthesis if OCP-L problem would arise</i></p> <p style="text-align: center;"> L                                      M                                            μ                                      μ      μ      μ  [ʔa] [nka    jil    yan] </p>	<p style="text-align: center;"> L                                      M                                            μ                                      μ      μ      μ  [ʔa] [nka    jil    yan] </p>
<p>f. <i>L-deletion to avoid an OCP-L problem</i></p> <p style="text-align: center;"> L                                      L                                            μ                                      μ      μ      μ  [ʔa] [ntu    sa    ne] </p>	<p style="text-align: center;"> L     μ      μ      μ      μ  [ʔa] [ntu    sa    ne] </p>

#### 4. Discussion/Open questions

- empty elements are assumed although we do not hear anything:
  - neighbouring elements do not behave as expected: a process is unexpectedly blocked (e.g. Dutch (2)) or triggered (e.g. Ahtna (3))
  - the portion containing the emptiness behaves unexpected (e.g. Turkish (7))
  - ...
- **theory-internal arguments** for emptiness along the lines: the analysis with empty elements is more elegant/natural/complex than the ones without it
- different types of EC should correspond to differences in the behavior of EC in identical contexts

- the theory-internal perspective: empty elements are a logical/necessary part of the theory/it's inventory (Strict CV in GP and Richness of the Base in OT)
- emptiness usually implies a default-concept: Empty elements are repaired/filled; the only difference is where they are repaired/filled (phonology or phonetics)
- the presence of empty elements is restricted: ECP, binary branching, licensing constraints
- different levels of emptiness?
  - Harris 1994, Complexity condition
  - John 2014: 5 “The main argument is that empty categories (i.e., empty nuclei, onsets and codas) can be represented with varying degrees of degeneracy, whether from one language to another or within the same language”
  - Oostendorp & Cavirani 2017: “We submit that we can establish a hierarchy of phonologically empty positions which follows from a simple representational assumption. The more structure a position has, the stronger is its licensing power (if licenser) or the higher its need for licensing (licensee)” [Empty V : some have more strength to license certain properties of neighbouring consonants than others.]
- does the *amount* of empty categories have an effect, beyond the obvious metaphorical aspect of the claim? Although emptiness implies less structure, it usually means more structure/more complexity: a structure is bigger if it includes different layers of empty categories

## References

- Akinlabi, Akinbiyi (2011), Featural affixes, in M.van Oostendorp, C. J.Ewen, E.Hume and K.Rice, eds, ‘The Blackwell Companion to Phonology’, Wiley Blackwell, chapter 82.
- Anderson, Stephen R. (1982), ‘The analysis of French shwa: Or, how to get something for nothing’, *Language* 3, 534–573.
- Archangeli, Diana (1988), ‘Aspects of underspecification theory’, *Phonology* 5, 183–207.
- Bendjaballah, Sabrina (1999), *Trois figures de la structure interne des gabarits*, PhD thesis.
- Bendjaballah, Sabrina (2001), ‘The negative preterite in Kabyle Berber’, *Folia Linguistica* 34(3-4), 185–223.
- Bendjaballah, Sabrina (2008), ‘Some remarks on upper austrian german diminutive formation’, Workshop on Templates, Paris 8.
- Bendjaballah, Sabrina and Martin Haiden (2003), ‘Templatic Architecture’, *Recherches Linguistiques de Vincennes* 32, 157–168.
- Bendjaballah, Sabrina and Martin Haiden (2008), A typology of emptiness in templates, in J.Hartmann, V.Hegedüs and H.van Riemsdijk, eds, ‘Sounds of Silence’, Elsevier, pp. 23–55.
- Bendjaballah, Sabrina and Martin Haiden (2013), The representational anomalies of floating markers: light prepositions in Taqbaylit of Chemini, in T.Biberauer and I.Roberts, eds, ‘Principles of linearization’, Mouton de Gruyter, Berlin, New York, pp. 331–375.
- Bérces, Katalin Balogné (2013), Emptiness in phonology, in M.Pellérdi and G.Reuss, eds, ‘Reverberations of Silence: Silenced Texts, Sub-Texts and Authors in Literature, Language and Translation’, Cambridge Scholars Publishing, Newcastle, pp. 257–280.
- Bermúdez-Otero, Ricardo (2012), The architecture of grammar and the division of labour in exponence, in J.Trommer, ed., ‘The morphology and phonology of exponence: The state of the art’, Oxford University Press, Oxford, pp. 8–83.
- Bye, Patrick and Peter Svenonius (2012), Non-concatenative morphology as epiphenomenon, in J.Trommer, ed., ‘The morphology and phonology of exponence: The state of the art’, Oxford University Press, Oxford, pp. 426–495.
- Cavirani, Edoardo and Marc van Oostendorp (2017), On silent markedness, in B.Samuels, ed., ‘Beyond Markedness in formal phonology’, John Benjamins.
- Charette, Monik (1990), ‘License to govern’, *Phonology Yearbook* 7(2), 233–253.
- Chomsky, Noam (1986), *Barriers*, MIT Press, Cambridge, Massachusetts.
- Clements, George N. and Samuel Jay Keyser (1983), *CV Phonology: A Generative Theory of the Syllable*, MIT press.

- Dresher, Elan B. (2003), The contrastive hierarchy in phonology, in 'Toronto Working Papers in Linguistics', Vol. 20, pp. 47–62.
- Encrevé, Pierre (1988), *La Liaison avec et sans enchaînement. Phonologie tridimensionnelle et usages du français*, Seuil.
- Fudge, E. (1976), Phonotactics and the syllable, in A. G. Juillard, ed., 'Studies offered to Joseph Greenberg, Vol. 2: Phonology', Saratoga, pp. 381–398.
- Godon, Elsa (1998), Aspects de la morphologie nominale du somali : la formation du pluriel, Master's thesis, Univ. Paris 7.
- Guerssel, Mohamed (1987), The Status of the Lexical Category Preposition in Berber: Implications for the Nature of the Construct State, in K. Hale, ed., 'Studies in Berber Syntax', Vol. 14, Center for Cognitive Science, MIT, Cambridge, Mass., chapter Lexicon Project Working Papers, pp. 159–190.
- Guerssel, Mohamed and Jean Lowenstamm (1990), 'The derivational morphology of the Classical Arabic verbal system'.
- Haegeman, Liliane (1991), *Government and binding theory*, Blackwell.
- Hall, Tracy Alan (1989), 'Lexical phonology and the distribution of German [ç] and [x]', *Phonology* 6(1), 1–17.
- Harris, John (1990), 'Segmental Complexity and Phonological Government', *Phonology Yearbook* 7(2), 255–300.
- Hartmann, Jutta M., Veronika Hegedüs and Henk van Riemsdijk (2008), Introduction, in J. M. Hartmann, V. Hegedüs and H. van Riemsdijk, eds, 'Sounds of Silence: Empty Elements in Syntax and Phonology', Elsevier, pp. 1–20.
- Heilig, Otto (1898), *Grammatik der ostfränkischen Mundart des Taubergrund*, Breitkopf und Härtel, Leipzig.
- Hyman, Larry (1985), *A theory of phonological weight*, Foris Publications, Dordrecht.
- Inkelas, Sharon (1995), The consequences of optimization for underspecification, in 'NELS 25', pp. 287–302.
- Ito, Junko and Armin Mester (2009), The extended prosodic word, in B. Kabak and J. Grijzenhout, eds, 'Phonological domains: Universals and Derivations', Mouton de Gruyter, pp. 135–194.
- John, Paul (2014), The Phonology of Empty Categories, PhD thesis, UQAM.
- Kager, René (1997), Rhythmic vowel deletion in optimality theory, in I. Roca, ed., 'Derivations and Constraints in Phonology', Oxford University Press, Oxford, pp. 463–499.
- Kager, René (1999), Consequences of Catalexis, in H. van der Hulst and J. van der Wiejer, eds, 'HIL Phonology Papers', The Hague: Holland Academic Graphics, pp. 269–298.
- Kaye, Jonathan (1990a), 'Coda Licensing', *Phonology Yearbook* 6, 301–330.
- Kaye, Jonathan (1990b), 'Government in phonology: The case of Moroccan Arabic', *The Linguistic Review* 6, 131–159.
- Kaye, Jonathan (1992), 'Do you believe in magic? the story of s+c sequences', *SOAS Working Papers in Linguistics and Phonetics* 2, 293–313.
- Kaye, Jonathan (2000), A users' guide to government phonology.
- Kaye, Jonathan and Jean Lowenstamm (1984), De la syllabité, in F. Dell and J.-R. Vergnaud, eds, 'Forme sonore du langage, structure des représentations en phonologie', Hermann, Paris, pp. 123–159.
- Kaye, Jonathan, Jean Lowenstamm and Jean-Roger Vergnaud (1990), 'Constituent structure and government in phonology', *Phonology* 7, 193–232.
- Kenstowicz, Michael and Jerzy Rubach (1987), 'The phonology of syllabic nuclei in Slovak', *Language* 63, 463–497.
- Kiparsky, Paul (1986), 'The Phonology of Reduplication'.
- Kiparsky, Paul (1991), 'Catalexis', ms. Stanford University.
- Kiparsky, Paul (2003), Syllables and moras in Arabic, in C. Féry and R. van de Vijver, eds, 'The Syllable in Optimality Theory', Cambridge University Press, Cambridge, pp. 147–182.
- Krämer, Martin (2000), 'Voicing alternations and underlying representations: the case of Breton', *Lingua* 9, 639–663.
- Krämer, Martin (2001), 'Yucatec Maya vowel alternations - harmony as syntagmatic identity', *Zeitschrift für Sprachwissenschaft* 20, 175–217.
- Kühnhammer, Klaus (2004), Isochrony in Austrian German, Master's thesis, Universität Wien.
- Kurusu, Kazutaka (2001), The Phonology of Morpheme Realization, PhD thesis, UC Santa Cruz.
- Lieber, Rochelle (1992), *Deconstructing Morphology*, Chicago: University of Chicago Press.
- Lin, Yen-Hwei (1997), 'Syllabic and moraic structures in Piro', *Phonology* 14, 403–436.
- Lowenstamm, Jean (2000), The No-Straddling Effect and its Interpretation, in J. Lecarme, J. Lowenstamm and U. Shlonsky, eds, 'Research in Afroasiatic Grammar', Benjamins, Amsterdam/Philadelphia, pp. 183–198.
- Lowenstamm, Jean (2008), On little n, root, and types of nouns, in J. Hartmann, V. Hegedüs and H. van Riemsdijk, eds, 'Sounds of Silence', North-Holland Linguistic Series, Elsevier, pp. 105–143.
- Onuma, Hitomi (2015), On the Status of Empty Nuclei in Phonology, PhD thesis, Tohoku Gakuin University.
- Pigott, Glyne L. (1999), 'At the right edge of words', *The Linguistic Review* 16, 143–185.
- Prince, Alan and Paul Smolensky (1993/2002), 'Optimality theory: Constraint interaction in generative grammar', [first circulated as Prince & Smolensky (1993) Technical reports of the Rutgers University Center of Cognitive Science], ROA 537-0802.
- Rice, Keren (2011), On the syllabification of right-edge consonants — evidence from Ahtna (Athapaskan), in S. van Ploch, ed., 'Living on the Edge. 28 Papers in Honour of Jonathan Kaye', de Gruyter Mouton, pp. 427–448.



- Rubach, Jerzy (1986), 'Abstract vowels in three-dimensional phonology: The yers', *The Linguistic Review* 5, 247–280.
- Saba Kirchner, Jesse (2010), Minimal Reduplication, PhD thesis, UC Santa Cruz.
- Scheer, Tobias (1999), 'Aspects de l'alternance schwa-zéro à la lumière de CVCV', *Recherches Linguistiques de Vincennes* 28, 87–114.
- Scheer, Tobias (2004), *A lateral theory of phonology*, Vol. Vol. 1: What is CVCV, and why should it be? of *Studies in Generative Grammar*, Mouton de Gruyter, Berlin.
- Seiler, Guido (2008), 'How to do things with moras: variation and change of quantity alternations across Upper German dialects', Paper presented at the International Morphology Meeting, Vienna.
- Selkirk, Elizabeth (1995), The prosodic structure of function words, in 'Papers in Optimality Theory', Vol. 18 of *University of Massachusetts Occasional Papers*, Amherst: University of Massachusetts, pp. 439–469.
- Spaelti, Phillip (1994), Weak edges and final geminates in Swiss German, in M.González, ed., 'Proceedings of NELS 24', GLSA, Amherst, MA, pp. 573–588.
- Spencer, Andrew (1986), 'A non-linear analysis of vowel-zero alternations in Polish', *Journal of Linguistics* 22, 249–280.
- Stonham, John (1994), *Combinatorial morphology*, John Benjamin, Amsterdam.
- Szypra, Jolanta (1992), 'Ghost segments in nonlinear phonology: Polish yers', *Langage* pp. 277–312.
- Tranel, Bernard (1995), The representation of French final consonants and related issues, in J.Amastae, G.Goodall, M.Phinney and M.Montalbetti, eds, 'Contemporary Research in Romance Linguistics: Papers from the XXII Linguistic Symposium on Romance Languages'.
- Tranel, Bernard (1996), Exceptionality in optimality theory and final consonants in French, in K.Zagona, ed., 'Grammatical Theory and Romance Languages: Selected papers from the 25th Linguistic Symposium on Romance Languages (LSRL XXV)', John Benjamins, Amsterdam, pp. 275–291.
- Travis, Lisa (1984), *Parameters and the effects of word order variation*, PhD Diss. MIT, Cambridge.
- Trommer, Jochen (2011), 'Phonological aspects of Western Nilotic mutation morphology', Habil. University of Leipzig.
- Trommer, Jochen (2012),  $\emptyset$ -exponence, in J.Trommer, ed., 'The morphology and phonology of exponence: the state of the art', pp. 326–354.
- van Oostendorp, Marc (1995), Vowel quality and phonological projection, PhD thesis, Katholieke Universiteit Brabant.
- van Oostendorp, Marc (2003), Schwa in phonological theory, in R. S.L.A. Cheng, ed., 'The Second Glot International State-of-the-article Book', Mouton de Gruyter.
- van Oostendorp, Marc (2005), The 1st person singular in dialects of Dutch, in L.Bateman and C.Ussery, eds, 'Proceedings of NELS 35', pp. 1–12.
- Villard, Stéphanie (2010), Zacatepec Chatino verb classification and aspect morphology, in 'Las memorias del Congreso de Idiomas Indígenas de Latinoamérica-IV', Archive of the Indigenous Languages of Latin America.
- Villard, Stéphanie (2015), The Phonology and Morphology of Zacatepec Eastern Chatino, PhD thesis, University of Texas at Austin.
- Villard, Stéphanie and Anthony C. Woodbury (2012), 'The typology of tone in San Marcos Zacatepec Eastern Chatino', SSILA Annual Meeting, Portland, Oregon, January 6, 2012.
- Wiese, Richard (1986), 'Schwa and the structure of words in German', *Linguistics* 24(4), 697–724.
- Wolf, Matthew (2007), For an autosegmental theory of mutation, in L.Bateman, M.O'Keefe, E.Reilly, and A.Werle, eds, 'UMOP 32: Papers in Optimality Theory III', GLSA, Amherst, MA, pp. 315–404.
- Yearley, Jennifer (1995), Jer vowels in Russian, in J.Beckman, L.Walsh Dickey and S.Urbanczyk, eds, 'Papers in Optimality Theory', GLSA Publications, Amherst, Mass., pp. 533–571.
- Yip, Moira (2002), *Tone*, Cambridge University Press.
- Zimmermann, Eva (2013), 'Vowel deletion as mora usurpation: the case of Yine', *Phonology* 30, 125–163.
- Zimmermann, Eva (2017a), 'The default vs. the underspecified: Floating tones in Zacatepec Chatino', talk, given at OCP 14, Düsseldorf, February 22, 2017.
- Zimmermann, Eva (2017b), *Morphological Length and Prosodically Defective Morphemes*, Oxford University Press, Oxford.
- Zoll, Cheryl (1994), Subsegmental parsing: floating features in Chaha and Yawelmani, in J.Merchant, J.Padgett and R.Walker, eds, 'Phonology at Santa Cruz 3'.
- Zoll, Cheryl (1996), Parsing below the segment in a constraint-based framework, PhD thesis, UC Berkeley.
- Zonneveld, Wim (1982), 'The descriptive power of the Dutch theme-vowel', *Spektator* 11, 342–365.